

Anbaugehäuse IP65 zu HC009S

Art. Nr.: **HCIP65**
Artikel: **Anbaugehäuse IP65 zu HC009S**
Preis: **34.90** CHF



Gehäuse aus transparentem Kunststoff passend für den Sensoren HC009S

- IP65. DxH= 135x84mm

Additional Images / Zusatz Bilder

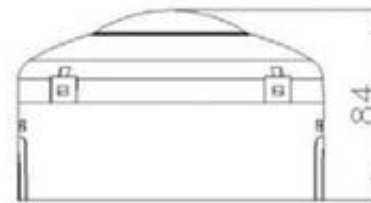
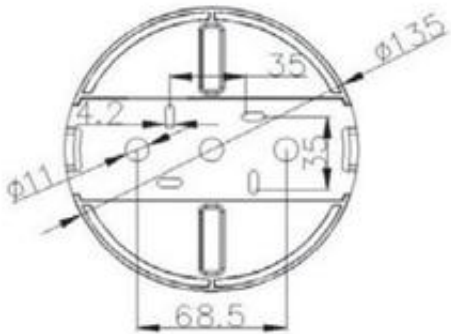

IP65 Mechanical structure